

**1**  
**DR2** **Roof Surface Detail**  
scale: 1/12" = 1'-0"

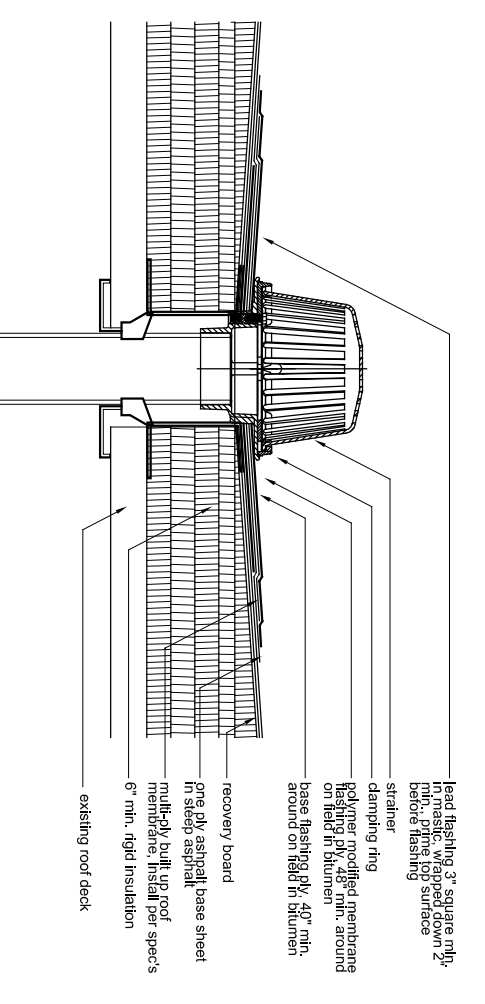

**2**  
**DR2** **Roof drain detail**  
scale: 1/12" = 1'-0"

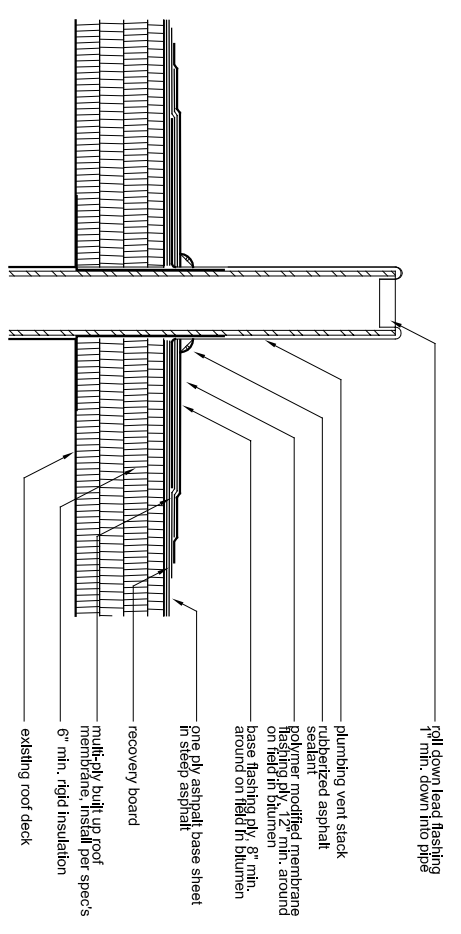

**3**  
**DR2** **Pipe Penetration**  
scale: 1/12" = 1'-0"

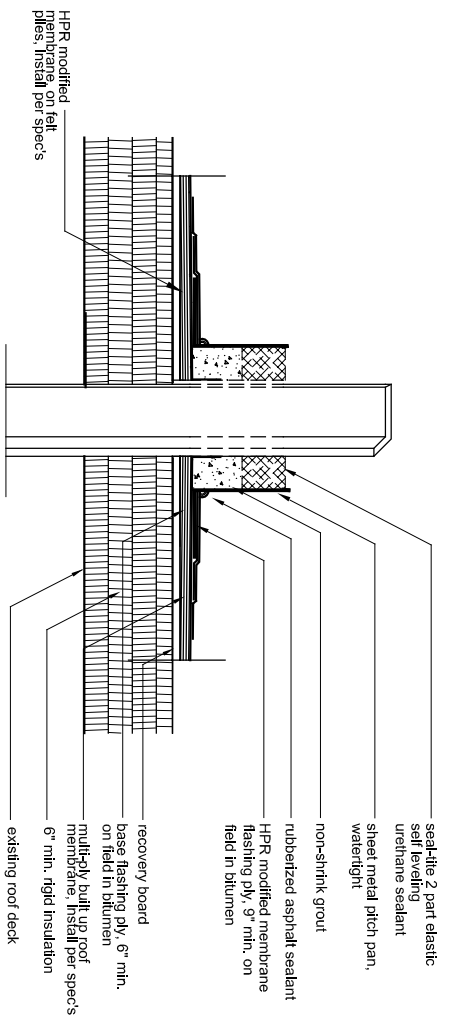

**4**  
**DR2** **Pitch Pan Detail**  
scale: 1/12" = 1'-0"

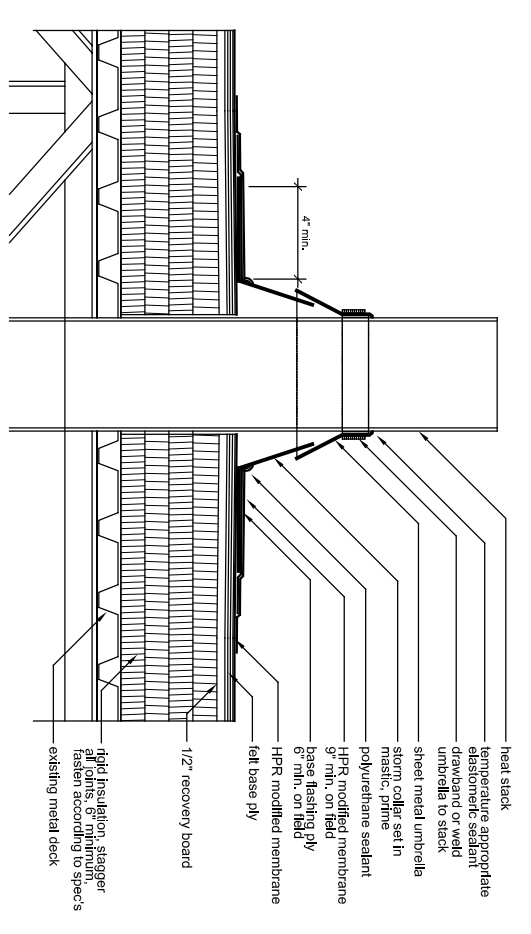

**5**  
**DR2** **Heat Stack**  
scale: 1/12" = 1'-0"

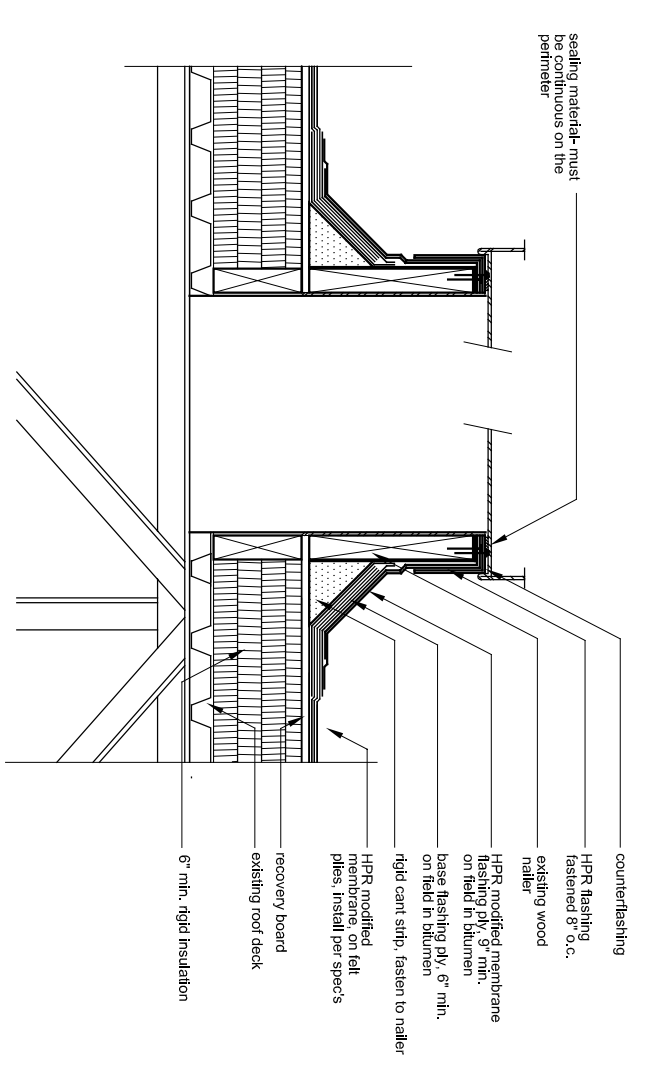

**6**  
**DR2** **Roof Curb Detail**  
scale: 1/12" = 1'-0"

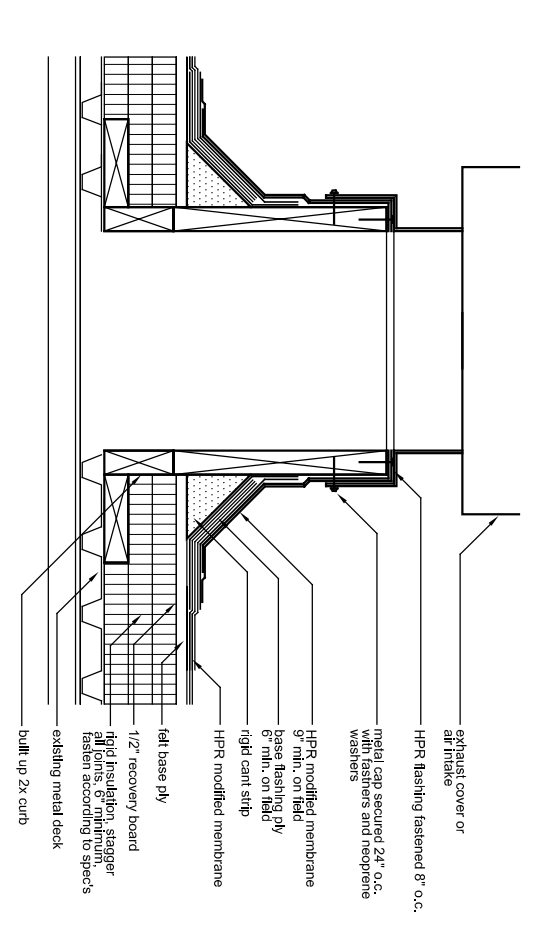

**7**  
**DR2** **Exhaust Fan**  
scale: 1/12" = 1'-0"

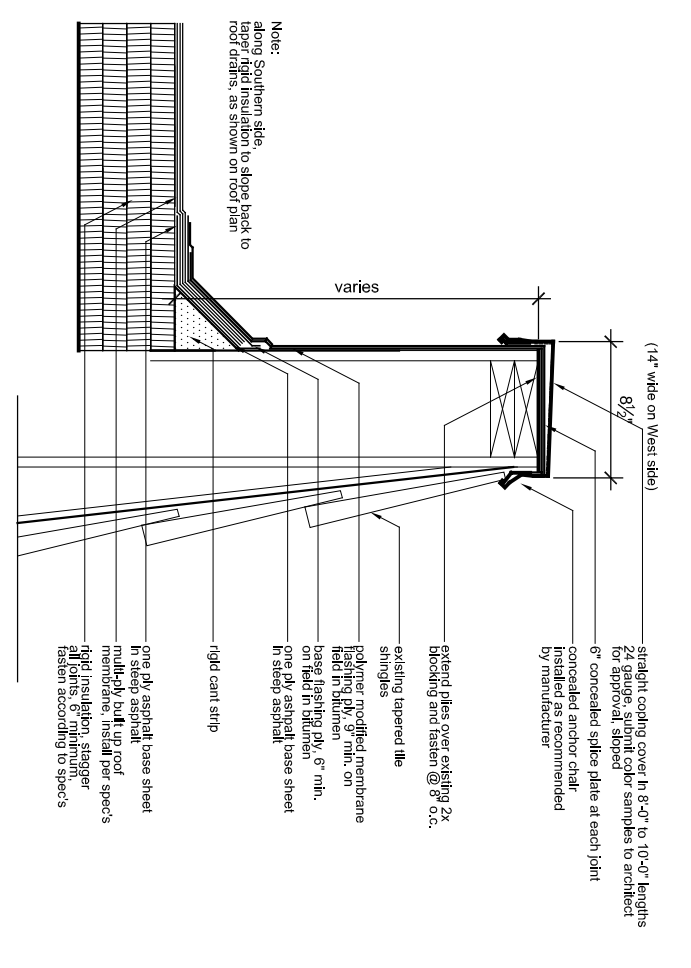

**8**  
**DR2** **Parapet Detail**  
scale: 1/12" = 1'-0"

**Colorado Mountain College  
Dillon Building Roof Renovation  
333 Fiedler, Dillon, Colorado**

**Construction**

**Roof Renovation Details**

Date: 07-31-15  
1506C-07-31-15

**DR2**